

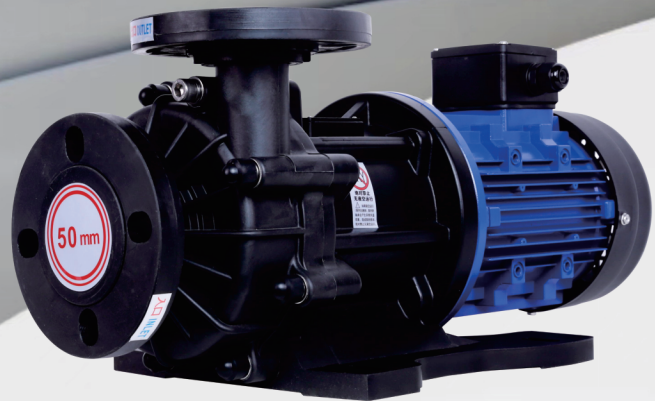

QHM Series Corrosion-Resistant Magnetic Drive Pumps

Exceptional Corrosion Resistance

High Performance, High Cost-effective, Customizable,
Increased Service Life.



GUANGDONG QEEHUA INDUSTRY EQUIPMENT CO., LTD.

High Flow Magnetic Drive Pump

No shaft seal design, and no risk of leakage.

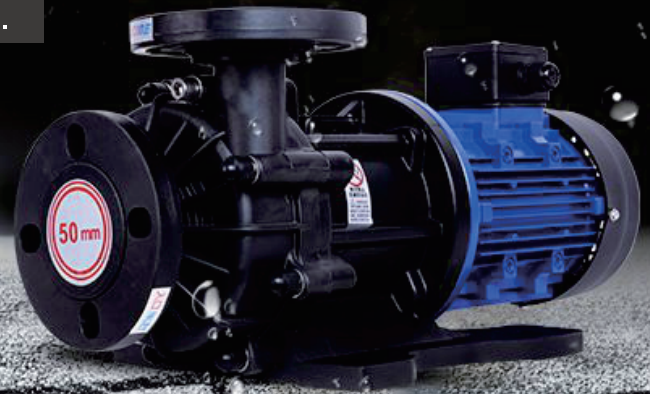

Series Models — 50Hz — 60Hz

Main Material	Model	Maximum flow rate (L/min)						Maximum head(m)				Specification Applicable Reference Specific Gravity Range
		200	400	600	800	1000	1200	10	20	30	40	
PPH/PVDF/CFR/ETFE	QHM-250	92						15	17			<1.2
	QHM-251	117	122					20	24			
	QHM-440	223	220					12	11			
	QHM-441	243	265					17	18			
	QHM-452	373	378					23	22			
	QHM-453	418	462					24	25			
	QHM-455	480	538					27	35			
	QHM-552	457	487					23	22			
	QHM-553	558	598					25	25			
	QHM-555	645	707					27	33			
	QHM-563	637	637					16.5	16.5			
	QHM-565	818	805					24	24.5			
	QHM-663	897	840					16	17			
	QHM-665	1037	1055					21	22			

- Medium Temperature: -10°C to +120°C, Medium Specific Gravity: 1 to 2, Operating Environment Temperature: -5°C to +50°C, Maximum Operating Altitude: 2,000 meters, Maximum Working Pressure: 5 Bar
- Testing Basis: The above performance specifications apply to water at 25°C/77°F conveyed at a normal speed. A performance tolerance of +5% exists. Pump performance may vary depending on the specific gravity and temperature of the process fluid being handled.

QHM Series Exploded View Diagram

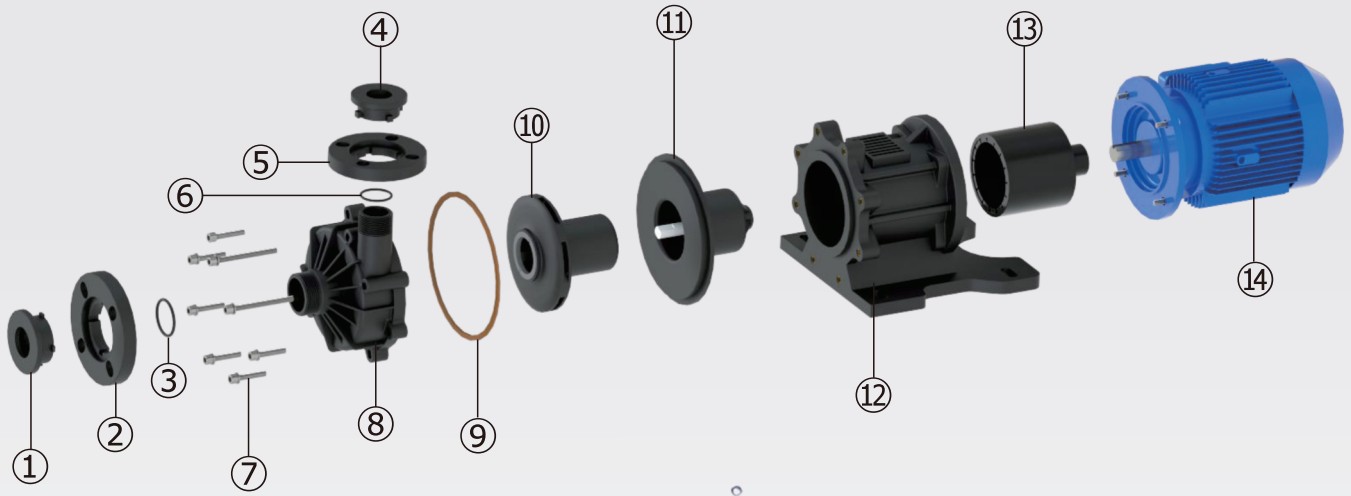

1. Inlet Flange Connector: PPH/PVDF/CFRETFE
2. Inlet Flange: GFRPP
3. Inlet Sealing O-Ring: EPDM/FKM/FFKM
4. Outlet Flange Connector: PPH/PVDF/CFRETFE
5. Outlet Flange: GFRPP
6. Outlet Sealing O-Ring: EPDM/FKM/FFKM
7. Fastening Screws: SUS304/SUS316/Ti

- * 8. Front Cover: Features a double-lip seal structure design. The connection type can be selected as flange, union or thread depending on different application requirements.
- * 9. Front and Rear Cover Sealing O-Rings: FKM is suitable for acidic chemicals and solvents. EPDM is suitable for alkaline chemicals and weak acids. FFKM can be optionally selected for any strong acids & alkalis and solvents.
- * 10. Impeller Assembly: Composed of an impeller + inner magnet (passive magnet). The inner magnet is integrally injection molded with encapsulation to ensure no leakage, no explosion, and a long service life. The impeller is scientifically designed, with deflection less than 0.2mm, to guarantee stability of flow rate and head pressure output. This can also avoid the problem of leakage because the impeller deflection is too large, resulting in the wear and deflection of the shaft and the sleeve leading to the rear cover being worn through.
- * 11. Rear Cover Assembly: Features a double-lip seal structure design. The rear cover material is PPH/PVDF/CFRETFE.
- 12. Baseplate: Integrally injection molded from PP + glass fiber for increased corrosion resistance and higher support strength, preventing corrosion of the fixing base by chemicals.
- 13. Drive Magnet: Vibration of the drive magnet is below 2.0mm/s. Rare earth strong magnet is used, non-demagnetizing, with a resin baking surface coating process to ensure extremely strong anti-corrosion performance.
- 14. Motor

· Note: Items marked with "*" are Wearing Parts.

Product Features

Stringent material selection and quality control processes are implemented throughout manufacturing. The product stability reaches the international first-class level

Non-explosive magnet patent: Ten years of experience and innovative injection molding technology help to prevent the inner magnet from cracking due to corrosive liquid penetration.

It can be equipped with intelligent protection devices to achieve anti-dry running, anti-overload, anti-phase loss, and improve product service life.



Model Description

QHM - F - 45 - 3 - C - C - V - 5 - V38 - A - F - A - A - S
 ① ② ③ ④ ⑤ ⑥ ⑦ ⑧ ⑨ ⑩ ⑪ ⑫ ⑬ ⑭

- ① Model No. : QHM
- ② Pump Material: F-PPH; P-PVDF; E-CFRETPE
- ③ Outlet calibre: 25-25*25mm; 44-40*40mm; 45-40*50mm; 55-50*50mm; 56-50*65mm; 66-65*65mm
- ④ Horsepower(HP): 0-1/2HP; 1-1HP; 2-2HP; 3-3HP; 5-5HP
- ⑤ Pump Shaft Material: C - Ceramic; S - SSIC; T - Titanium
- ⑥ Bearing Material: C - Carbon; S - SSIC; P - PTFE
- ⑦ Seal material: E-EPDM; V-FKM; F-FFKM
- ⑧ Frequency: 5-50Hz; 6-60Hz
- ⑨ Voltage: V38-3Ø/380V; V41-3Ø/415V; V44-3Ø/440V; V48-3Ø/480v; V66-3Ø/660V; V32-3Ø/220V; V22-1Ø/220V
- ⑩ Specific Gravity: A-1.0-1.2; B-1.3; C-1.4; D-1.5; E-1.6; F-1.7; G-1.8; H-1.9; I-2.0
- ⑪ Connection Options: F-Flange; U-Union; S-Screw
- ⑫ Motor Options: A-IE3 Standard Efficiency Motor; B- IE4 Standard Efficiency Motor; C-IE5 Standard Efficiency Motor; D - Variable frequency motor; E - IE3, BT4 explosion-proof motor; F - IE4, BT4 explosion-proof motor; G - IE5, BT4 explosion-proof motor; H - IE3, CT4 explosion-proof motor; I - IE4, CT4 explosion-proof motor; J - IE5, CT4 explosion-proof motor; K - Permanent-magnet variable frequency motor; L - BT4 explosion-proof variable frequency motor; M - CT4 explosion-proof variable frequency motor
- ⑬ Motor Protection Class: A-IP54; B-IP55; C-IP56; D-IP65
- ⑭ S-Standard; N-Non-Standard

Product Specification Sheet

Model	Inlet/Outlet (mm)	Maximum Flow				Maximum Head(m)		Specification Applicable Reference Specific Gravity Range	Power		Weight (kg)
		50Hz		60Hz		50Hz	60Hz		HP	KW	
		(L/min)	(m³/h)	(L/min)	(m³/h)						
QHM-250	25/25	92	5.5	100	6.0	15.0	17.0	<1.2	0.5	0.37	14.8
QHM-251	25/25	117	7	122	7.3	20.0	24.0	<1.2	1	0.75	19.1
QHM-440	40/40	223	13.4	220	13.2	12.0	11.0	<1.2	0.5	0.37	13.7
QHM-441	40/40	243	14.6	265	15.9	17.0	18.0	<1.2	1	0.75	20.0
QHM-452	50/40	373	22.4	378	22.7	23.0	22.0	<1.2	2	1.5	28.0
QHM-453	50/40	418	25.1	462	27.7	24.0	25.0	<1.2	3	2.2	30.7
QHM-455	50/40	480	28.8	538	32.3	27.0	35.0	<1.2	5	4	46.3
QHM-552	50/50	457	27.4	487	29.2	23.0	22.0	<1.2	2	1.5	28.2
QHM-553	50/50	558	33.5	598	35.9	25.0	25.0	<1.2	3	2.2	30.9
QHM-555	50/50	645	38.7	707	42.4	27.0	33.0	<1.2	5	4	46.5
QHM-563	65/50	637	38.2	637	38.2	16.5	16.5	<1.2	3	2.2	31.0
QHM-565	65/50	818	49.1	805	48.3	24.0	24.5	<1.2	5	4	46.6
QHM-663	65/65	897	53.8	840	50.4	16.0	17.0	<1.2	3	2.2	31.4
QHM-665	65/65	1037	62.2	1055	63.3	21.0	22.0	<1.2	5	4	46.8

- Medium Temperature: -10°C to +120°C, Medium Specific Gravity: 1 to 2, Operating Environment Temperature: -5°C to +50°C, Maximum Operating Altitude: 2,000 meters, Maximum Working Pressure: 5 Bar
- Testing Basis: The above performance specifications apply to water at 25°C/77°F conveyed at a normal speed. A performance tolerance of +5% exists. Pump performance may vary depending on the specific gravity and temperature of the process fluid being handled.

QHM - 250/251/440/441/452/453/455 552/553/555/563/565/663/665

- Maximum flow rate: 92-1055L/min
- Maximum head: 11-35m

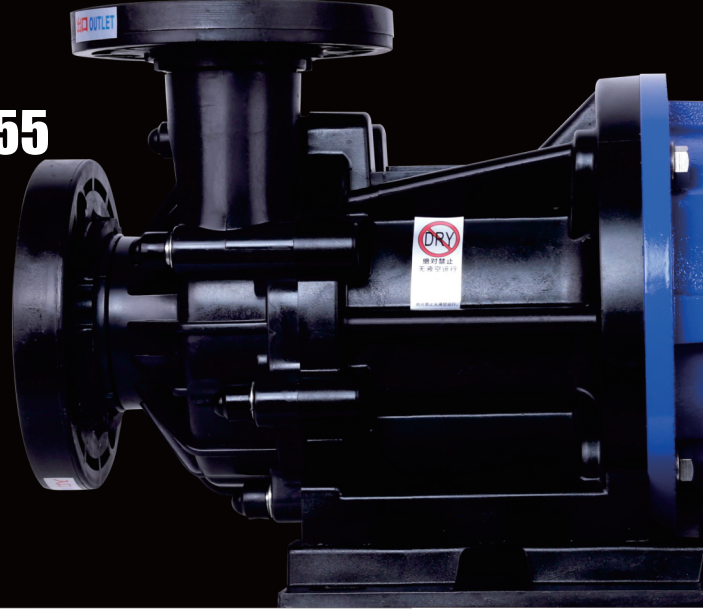

Structural drawings and materials

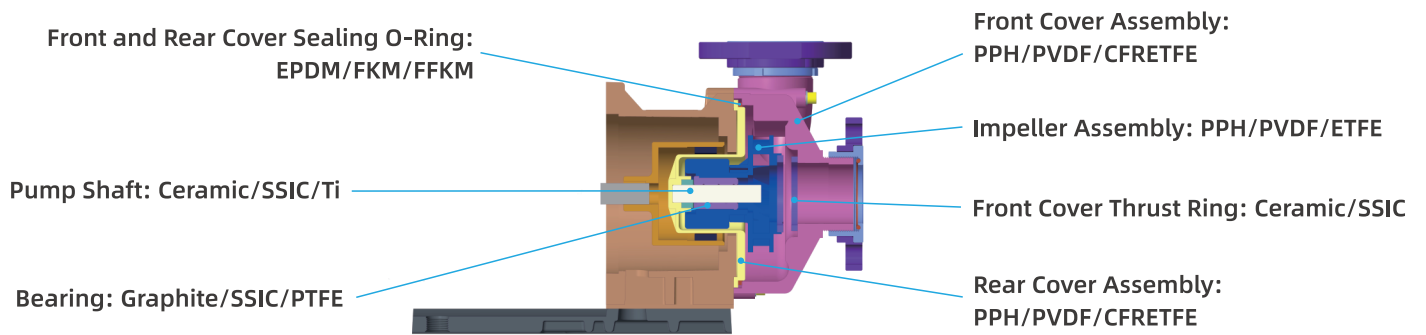

Performance Curve

Head&Flow Efficiency Shaft Power

QHM-441 Performance Curve

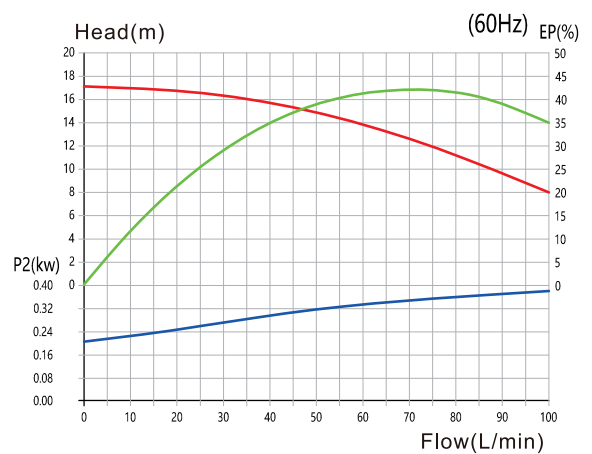
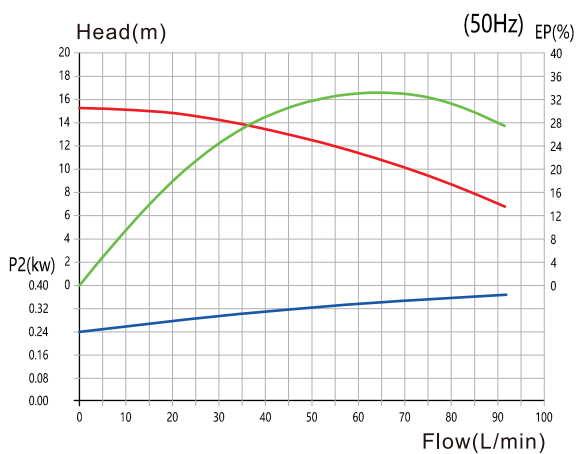

QHM-251 Performance Curve

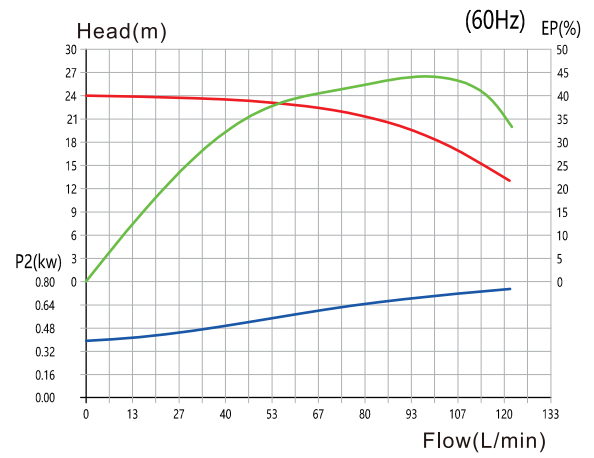
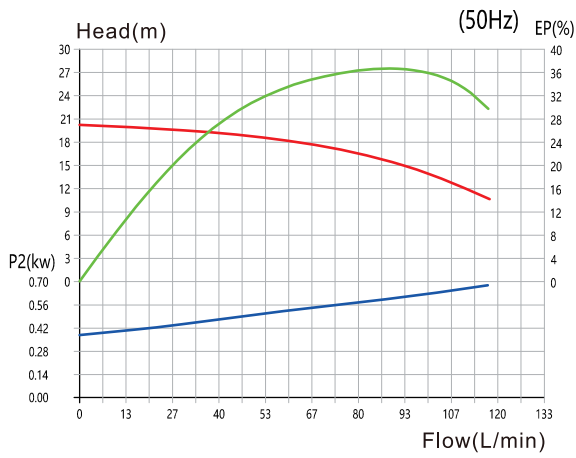

QHM-440 Performance Curve

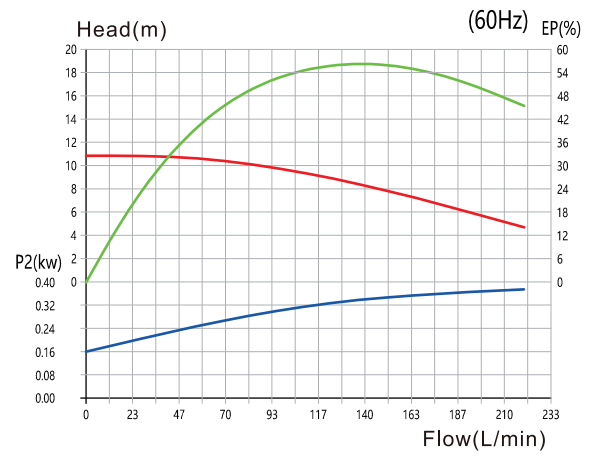
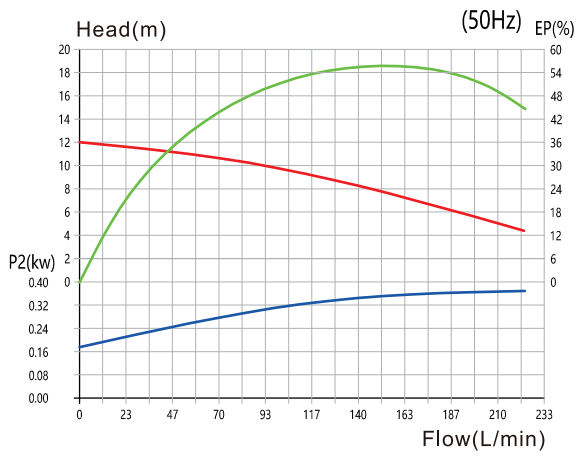

QHM-441 Performance Curve

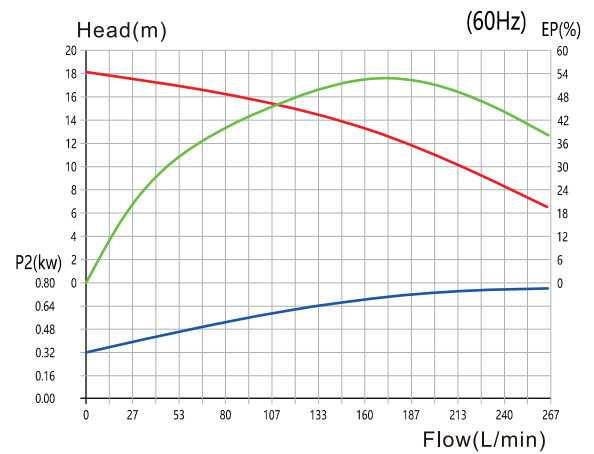
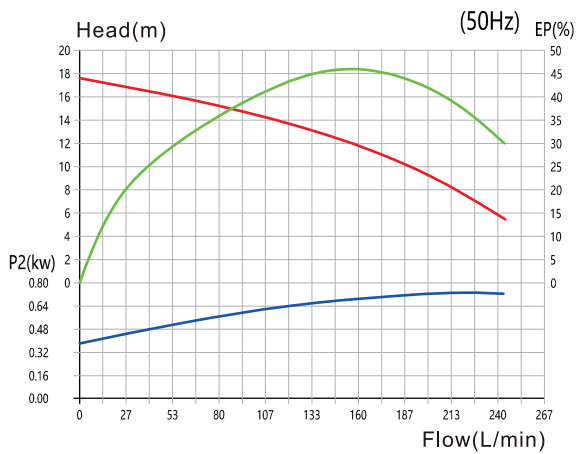

QHM-452 Performance Curve

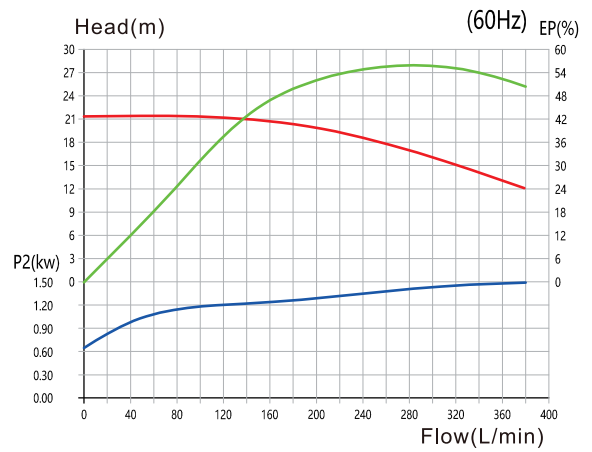
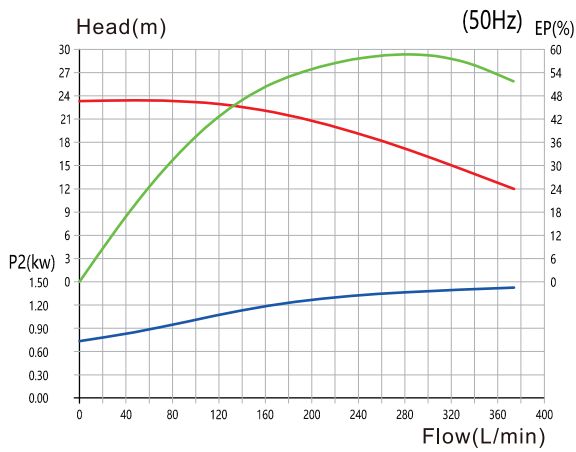

QHM-453 Performance Curve

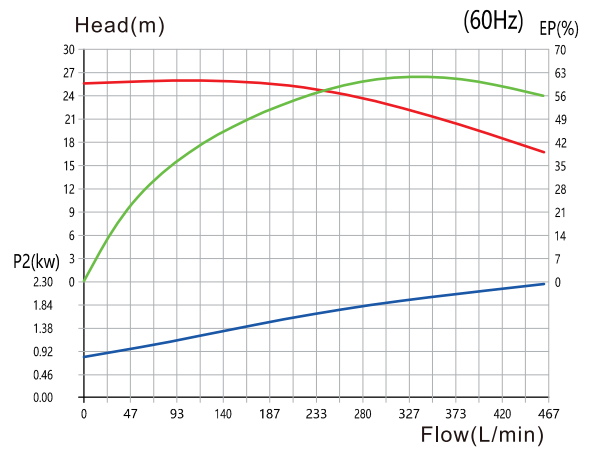
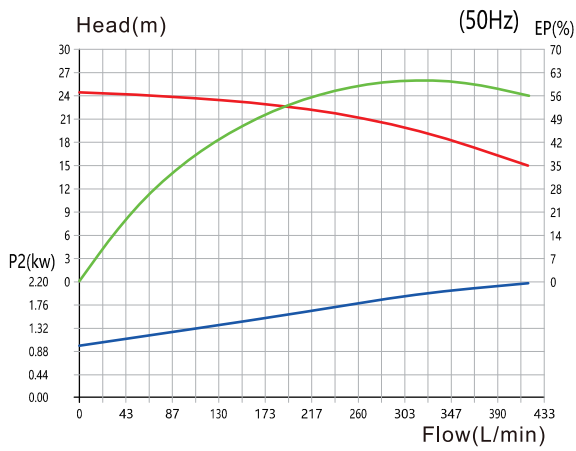

QHM-455 Performance Curve

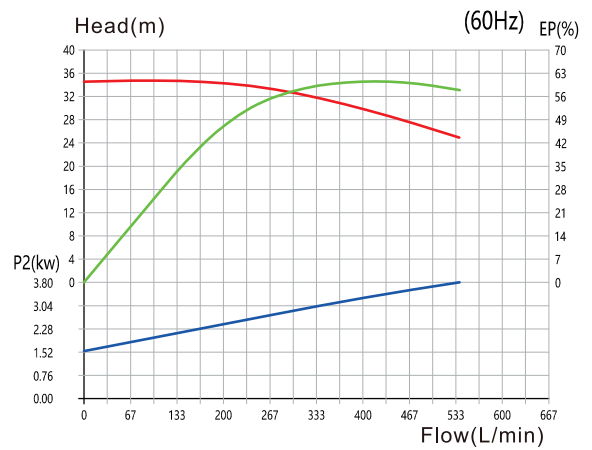
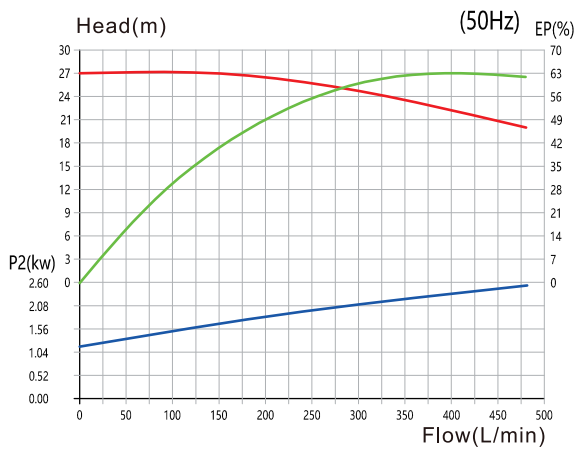

QHM-552 Performance Curve

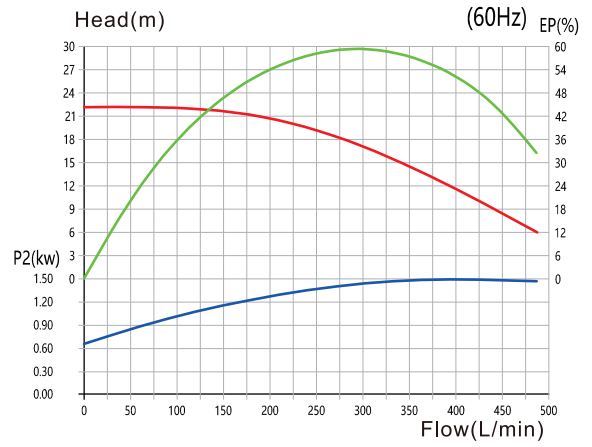
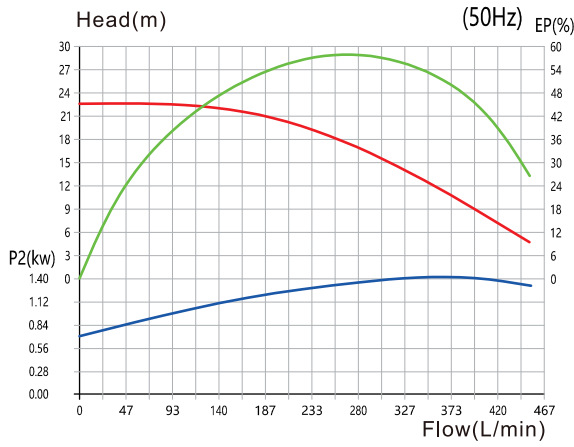

QHM-553 Performance Curve

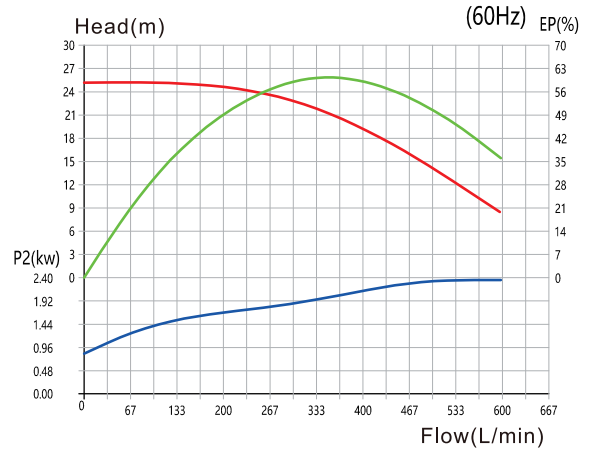
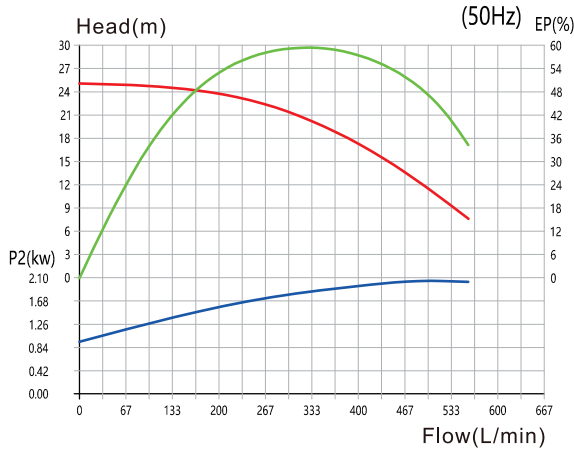

QHM-555 Performance Curve

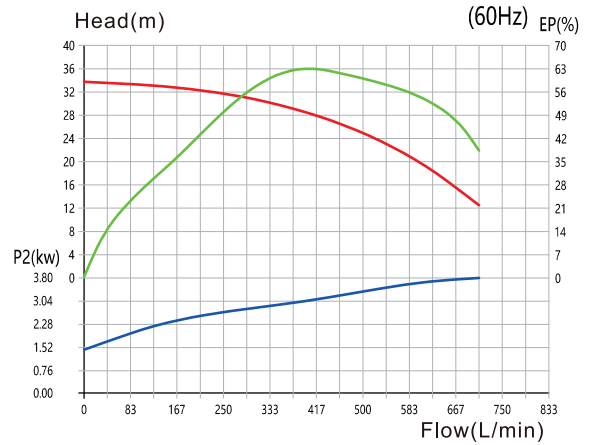
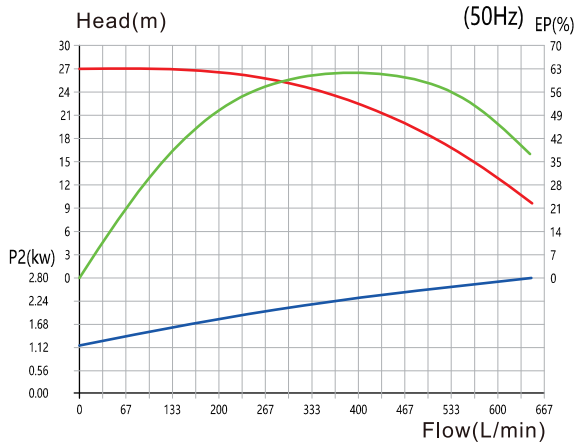

QHM-563 Performance Curve

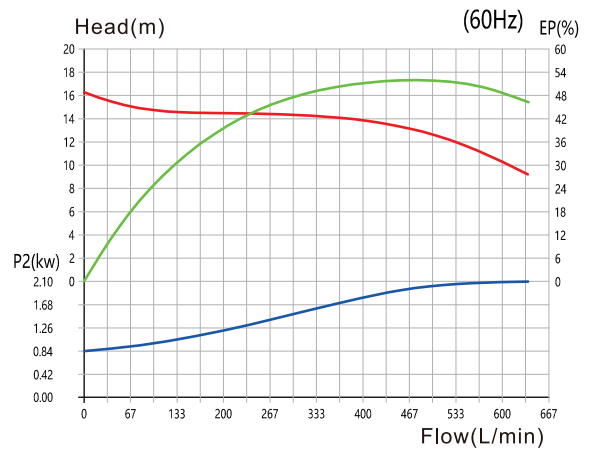
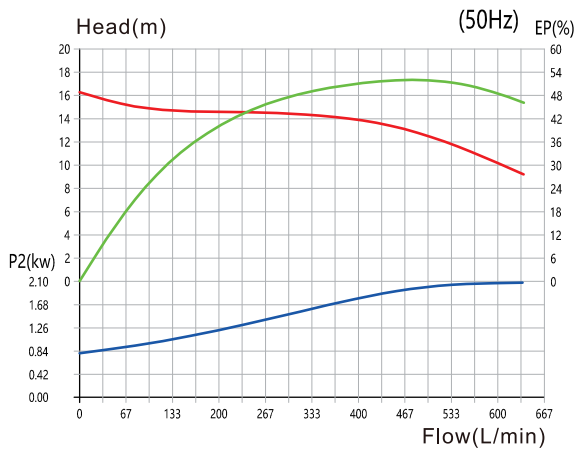

QHM-565 Performance Curve

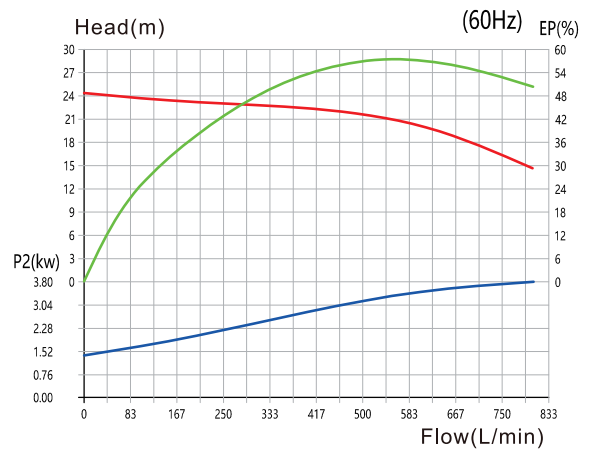
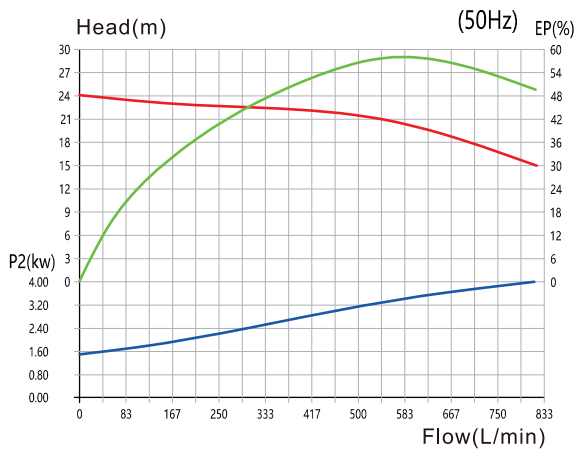

QHM-663 Performance Curve

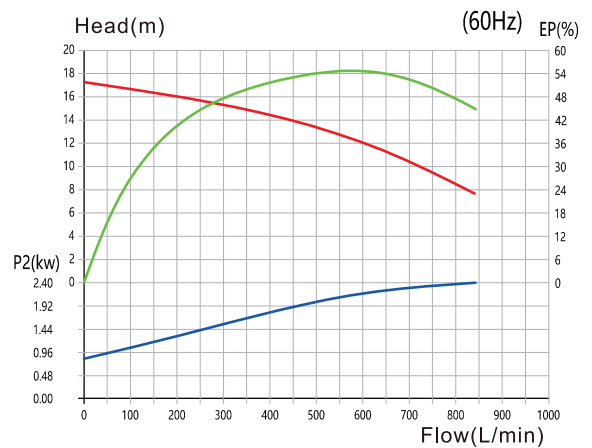
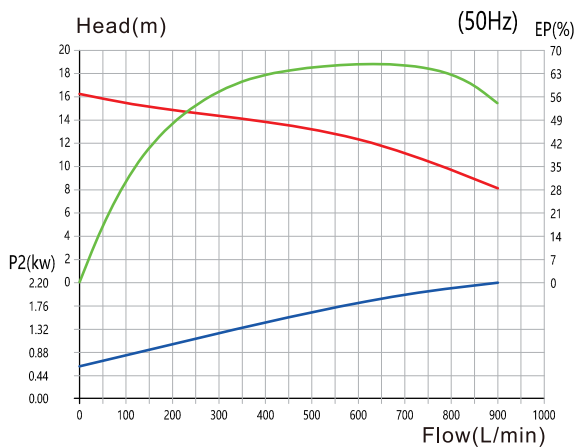

QHM-665 Performance Curve

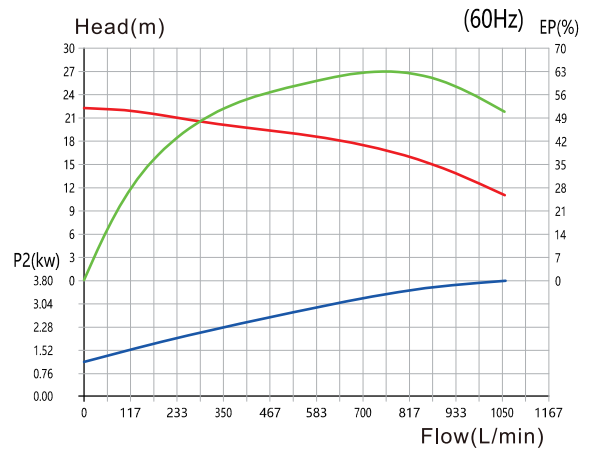
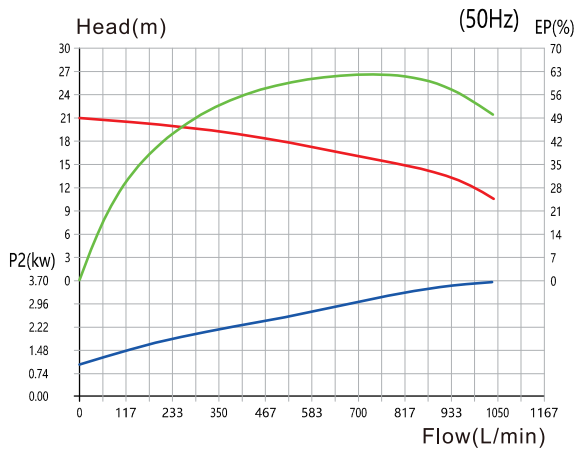

Overall Dimensions

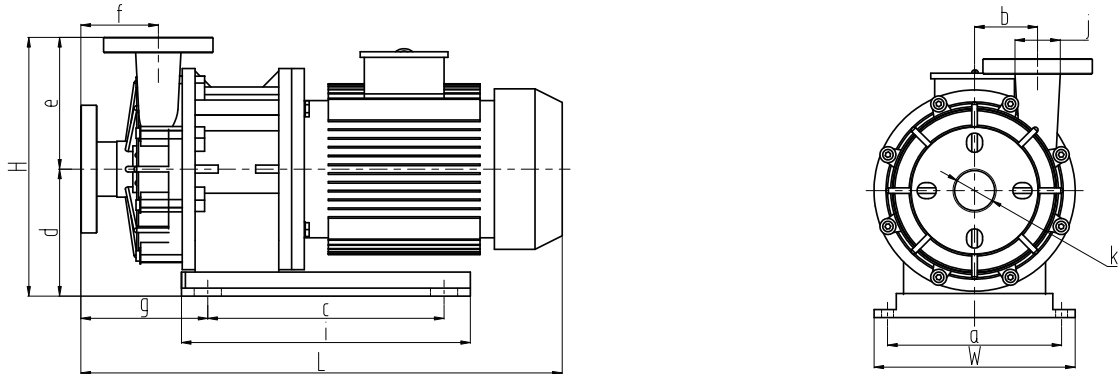

Model	L	H	W	a	b	c	d	e	f	g	i	j	k
QHM-250	436	257	192	146	65	132	118	140	91	166	206	∅21	∅21
QHM-251	459	254	192	128	67	131	114	140	91	161	214	∅21	∅21
QHM-440	434	223	141	111	50	79	99	124	89	160	134	∅36	∅36
QHM-441	524	257	161	132	53	132	115	142	107	181	198	∅36	∅36
QHM-452	575	256	268	211	65	204	115	141	95	157	270	∅36	∅44
QHM-453	575	256	268	211	65	204	115	141	95	157	270	∅36	∅44
QHM-455	575	256	268	211	65	204	115	141	95	157	270	∅36	∅44
QHM-552	575	256	268	211	65	204	115	141	95	157	270	∅36	∅44
QHM-553	635	280	260	227	65	270	139	141	95	149	325	∅36	∅44
QHM-555	635	280	260	227	65	270	139	141	95	149	325	∅36	∅45
QHM-563	589	273	268	211	65	204	114	159	112	174	270	∅50	∅65.5
QHM-565	649	296	260	227	65	270	137	159	112	163	325	∅50	∅65.5
QHM-663	560	291	262	208	80	200	121	170	95	182	275	∅66	∅66
QHM-665	617	335	252	218	80	295	159	176	100	175	362	∅66	∅66

● Note: This is the dimensions of the PPH material pump.

Installation Diagram

For heat exchangers

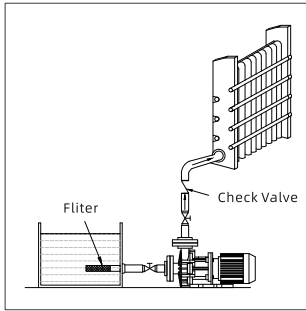

Reaction tanks or filter compressors

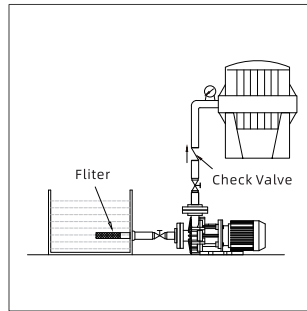

For equipment lines or exhaust gas cleaning towers

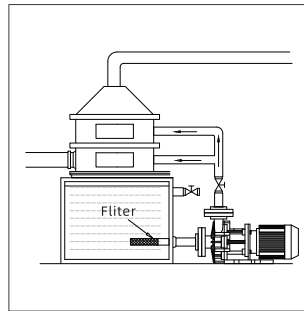

Warning of incorrect use

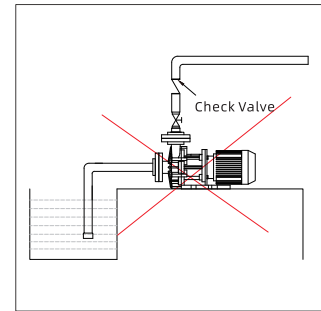

Safety Precautions

Safety Warning!

1. There is risk of electrical shock if operated without power being isolated.
2. Do not operate pump unless it is properly grounded and equipped with leakage protection.
3. Only qualified personnel should perform electrical work.
4. Wear appropriate protective equipment when handling chemicals to prevent injury from hazardous fluids.
5. Toxic substances handled by the pump may cause poisoning.
6. Operate pump only as intended and within specified operating conditions.
7. Motor and pump surfaces will be very hot during operation - avoid direct contact.
8. Unauthorized modifications to the pump are prohibited and may result in serious accidents. The manufacturer accepts no liability for damage caused by non-approved or non-written specifications modifications.
9. The magnetic drive pump contains strong magnets. Its powerful magnetic field may significantly impact individuals wearing electronic devices such as pacemakers.

Important note!

1. Do not operate the pump without liquid. Running the pump dry will cause the pump components to rub against each other and overheat, which will damage the pump. (Operating the pump with the suction valve fully closed is also considered dry running.)
2. Immediately stop operation if any abnormality or hazard is detected and resolve any issues found before restarting.
3. Only qualified personnel should operate the pump.
4. Only operate the pump within the specified voltage range; operation outside this may damage the pump or cause fire.
5. The pump location should have protections against fluid splashing or leaks.
6. Toxic substances handled by the pump may cause poisoning; ensure adequate ventilation.
7. Do not forcefully scrape, damage, squeeze or stretch electrical cables. Damaged cables can cause fire or electrical shock.
8. Enclosed pumps can cause fire or mechanical failure due to heat buildup during operation.
9. When maintenance is being performed on the pump, take precautions to prevent other operators from accidentally energizing it. Place a warning sign by the power switch to indicate maintenance is in progress.
10. Fluids discharged from the pump may contain toxic or hazardous chemicals and must be directed safely to approved storage containers.



www.qeehuapump.com



www.qeehua-pump.com

HEAD OFFICE IN SOUTH CHINA:

GUANGDONG QEEHUA INDUSTRY EQUIPMENT CO., LTD.

Address: No.8, East Chenwu Road, Houjie Town, Dongguan City, Guangdong Province, China.

SUBSIDIARY CORPORATION:

DONGGUAN EVER POPULAR IMPORT AND EXPORT CO., LTD.

No. 1301&1302, Tianan Cyber Park, No.1 Huangjin Road, Nancheng District,
Dongguan City, Guangdong Province, China.

SUBSIDIARY CORPORATION:

JIANGXI QEEHUA FLOW TECHNOLOGY CO., LTD.

Address: Room 110, Building 3, Hengke Industrial Park phase 1,
Economic and Technological Development Zone, Ganzhou City, Jiangxi Province, China.

SUBSIDIARY CORPORATION:

SUZHOU QEEHUA PUMP INDUSTRY CO., LTD.

Address: Room 221, Kezheng Building, No. 16, Nantiancheng Road, High - speed Railway New Town,
Xiangcheng District, Suzhou City.

SUBSIDIARY CORPORATION:

CHENGDU QEEHUA FLUID TECHNOLOGY CO., LTD.

No. 08, 3rd Floor, Building 3, No. 1108 Shengbang Street, High tech Zone, Chengdu City, Sichuan Province, China.



Copyright belongs to our company
Product specifications and technical indicators are subject to change without prior notice.

2026.03.06